

mod. **CV** Drums vertical lifting and turning with locking device

CV clamp is used for upright lifting and turning from horizontal to vertical position steel drums.

The clamp has an automatic spring that acts as a locking device, that grips and holds firmly the rim of the drum for vertical transportation.

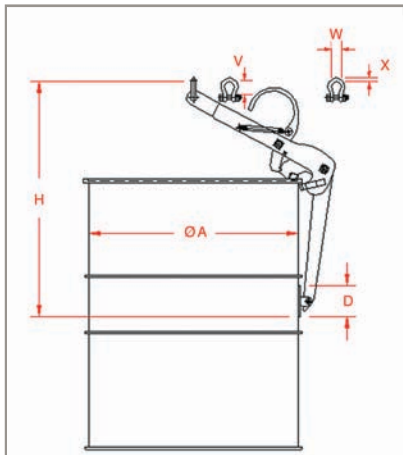

CODE	CAPACITY TON	A	D	H	V	W	X	WEIGHT KG
		MM	MM	MM	MM	MM	MM	
CV00600	0,6	560-610	100	853	26	31	12	8,0