

mod. **CS** Screw clamp with articulated shackle

"CS" clamp is capable to handle steel plates from horizontal through an 180° arch and may be used to adjust clamp to various thickness of materials to be lifted.

Place the clamp on the plate maintaining 4÷5 mm clearance between the back of the jaw and the plate to be lifted.

Tighten screw making sure that gripping surfaces are parallel to the surfaces of the member to be lifted and not partially on and off the edge of the plate.

This clamp is limited to 10° sideloading.

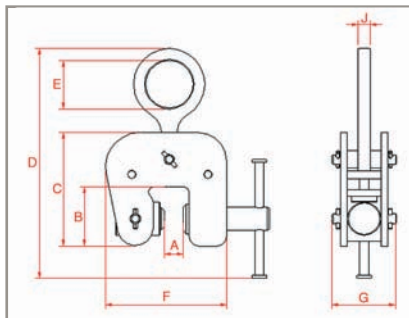
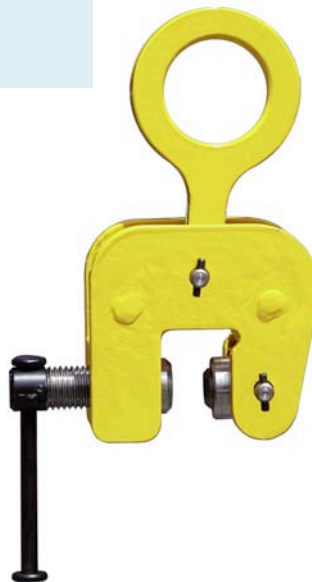

| CODE | CAPACITY TON | A | B | C | D | E | F | G | J | WEIGHT KG |
|----------|-----------------|--------|-----|-----|-----|-----|-----|-----|----|--------------|
| | | MM | MM | MM | MM | MM | MM | MM | MM | |
| CCS00500 | 0,5 | 0 - 19 | 60 | 115 | 260 | 60 | 123 | 65 | 12 | 2,3 |
| CCS01500 | 1,5 | 0 - 32 | 73 | 140 | 295 | 65 | 163 | 80 | 15 | 4,5 |
| CCS03000 | 3,0 | 0 - 51 | 125 | 220 | 430 | 100 | 255 | 125 | 20 | 6,5 |
| CCS06000 | 6,0 | 0 - 64 | 110 | 160 | 320 | 100 | 205 | 100 | 20 | 15 |